

Product Data Sheet

OUTLETS AND LEAF GUARDS

Accessories

Axter Ltd offers a range of high quality roof drain accessories designed for use in conjunction with Axter roof waterproofing systems on new build and refurbishment projects.

Parapet outlet

Rainwater outlets are manufactured from 0.7mm stainless steel in a choice of diameters, with a factory bonded flange if required to provide an excellent bonding area with the relevant Axter waterproofing system.

Rainwater outlets fitted with a flange of high quality waterproofing membrane are available in the following sizes:

Outlet Ø: 50mm, 62mm, 75mm, 95mm, 110mm, 145mm, 160mm

Pipe Length: 400mm or 600mm (up to 110mm)

SBS bitumen membrane flange 500mm square suitable for use with the full range of Axter reinforced bitumen membrane (RBM) and hot melt structural waterproofing systems. On our Dual Outlet a bitumen flange is fitted at air and vapour control layer (AVCL) level.

PVC membrane flange 350mm square suitable for use with Axter Ecoflex PVC single ply waterproofing systems.

Rainwater outlets with no flange are available in the following sizes:

Outlet Ø: 50mm, 75mm, 95mm, 110mm

Pipe Length: 400mm

These outlets are suitable for use with Axter cold applied liquid waterproofing membranes (Starcoat QC and Starcoat PMMA).



Rainwater outlet – performance

Outlet Ø	To suit pipe (in mm)*	Pitch <1:80**	Pitch >1:80**
50mm	58-64	50-90m ² roof area	20-40m ² roof area
62mm	69-73	60-160m ² roof area	20-65m ² roof area
75mm	82-95	90-160m ² roof area	35-70m ² roof area
95mm	103-109	105-200m ² roof area	45-85m ² roof area
110mm	120-128	135-245m ² roof area	55-100m ² roof area
145mm	150-157	250-300m ² roof area	100-125m ² roof area
160mm	170-178	300-370m ² roof area	125-155m ² roof area

(Also available in 40, 70, 80, 90 and 125mm external diameter).

* Internal diameter of the pipe.

**In refurbishment scenario.

Certain sizes (62mm, 95mm and 145mm) are more commonly used in refurbishment applications and the 'O' ring supplied provides an excellent seal whilst still allowing for movement.



Parapet outlet

Parapet outlets are manufactured from 0.7mm stainless steel in a choice of diameters, with a factory bonded flange if required to provide an excellent bonding area with the relevant Axter waterproofing system.

Parapet outlets fitted with a flange of high quality waterproofing membrane to ensure excellent bonding with the Axter Ltd waterproofing system installed are available in the following sizes:

Outlet Ø: 50mm, 75mm, 110mm,

Pipe Length: 400mm or 600mm

SBS bitumen membrane flange 500mm square suitable for use with the full range of Axter reinforced bitumen membrane (RBM) and hot melt structural waterproofing systems. On our Dual Outlet a bitumen flange is fitted at AVCL level.

PVC membrane flange 350mm square suitable for use with Axter Ltd Ecoflex/Ecoline PVC single ply waterproofing systems.

Parapet outlets with no flange are available in the following sizes:

Outlet Ø: 110mm

Pipe Length: 400mm

These outlets are suitable for use with Axter cold applied liquid waterproofing membranes (Starcoat QC and Starcoat PMMA).



Parapet outlet – performance

Parapet outlet	Pitch < 1:80	Pitch > 1:80
(b) 50mm (a) 40x40mm	20-28m ² roof area*	6-11m ² roof area*
(b) 75mm (a) 65x65mm	32-44m ² roof area*	11-18m ² roof area*
(b) 110mm (a) 90x90mm	48-66m ² roof area*	18-27m ² roof area*

(a) = mouth of the outlet where the flange is, (b) = diameter of the pipe.
*Estimated figures, exact area dependent on the location in the country.
Contact Axter Ltd for more information.

Wide parapet outlet

The wide parapet outlet (currently only available with an SBS flange) is 200mm x 60mm (outside dimensions are 215mm x 70mm and used where an increased flow rate (2.02l/s) is required. A 90° pipe angle (made to order) and extra-large leaf guard are also available to be used with this unit.

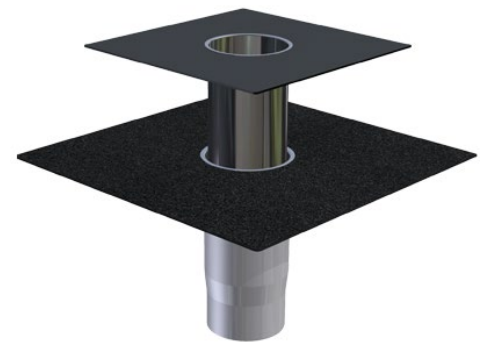

DUAL OUTLETS

The dual outlet consists of two parts. The lower outlet connects to the AVCL to create an effective seal. The upper outlet is a standard rainwater outlet that is fitted through the insulation and into the lower outlet, creating a watertight connection.

Outlet Ø*	To suit pipe Ø**
75mm	82 - 95mm
110mm	120-128mm
125mm	135-143mm
160mm	170-178mm

* Narrowest part of the bottom unit.
** In refurbishment scenario.

110mm sump outlet

Sump outlets are specifically designed for through walls applications or parapets where a high flow rate is required and are supplied with our Hyflow leaf guard as standard.

The sump outlet has an outstanding flow rate of 6.1l/s.

As recommended by UK design standard BS EN 12056:3-2000 with a water depth of 35mm.

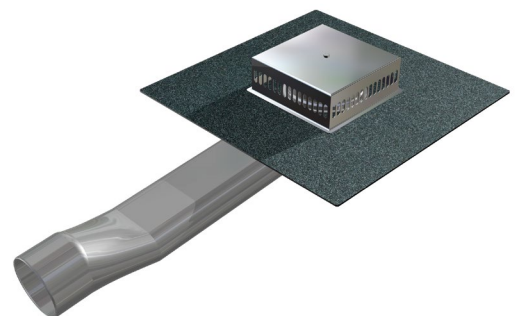

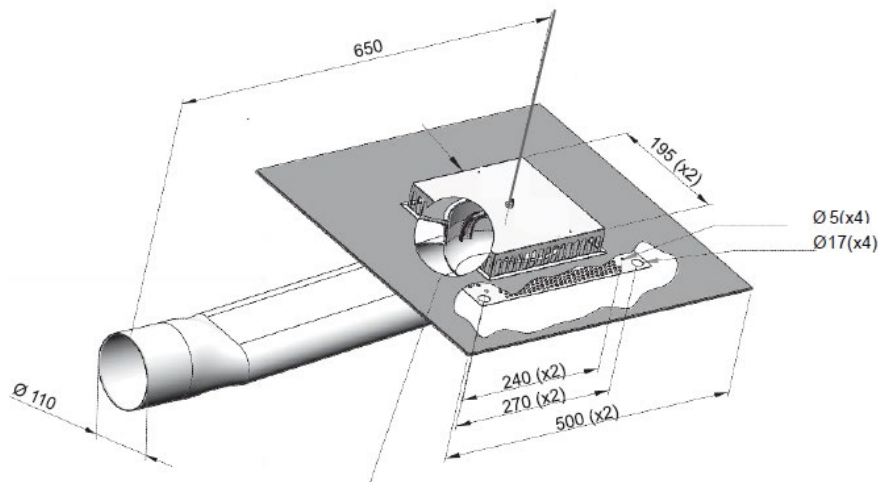

A minimum of 2 outlets is required (regardless of the roof size) with water depth of 35mm.

As recommended by UK design standard BS EN 12056:3-2000.

Periodic inspection should be carried out to ensure that the outlets are free of debris, leaves and gravel which could impair the performance of the drainage system.

Leaf guards & accessories

Hyflow leaf guard

The 304 grade stainless steel Hyflow leaf guard is a new high performance leaf guard designed to be used with Axter rainwater outlets. Its use increases flow rate by over 50% compared to standards leaf guards. Size: 245 x 245mm.



Universal leaf guard

The stainless steel universal leaf guard is a solid and effective leaf guard which securely clamps to the inside of the outlet stem. Suits all sizes of rainwater outlets.

Sizes: Two sizes available: 210 x 210mm and 325 x 325mm.



Parapet leaf guard

The parapet leaf guard is a solid and effective leaf guard which is securely attached to the inside of the outlet and is fully adjustable to fit all three parapet outlet sizes.

Size: 140 x 225mm and 140 x 325mm (to be used with the wide parapet leaf guard).

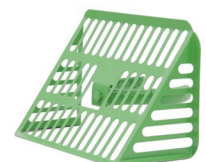

Cylindrical leaf guard

The stainless steel cylindrical leaf guard is mainly used for ballasted roofs.

Sizes: ten standard sizes available: 50 to 160mm.



Inverted / ballast guard

The high grade impact resistant stainless steel guard prevents aggregates and debris from blocking roof outlets on inverted flat roof systems.

The lid is removable and the guard can be cut down to match insulation thickness (up to 260mm). Available for 62, 75, 95, 110mm outlets (other diameter and length available to be made to order.)



Balcony leaf guard

The balcony leaf guard is used for balconies and other areas exposed to light foot traffic.

Suits all sizes of rainwater outlets up to 110mm.



Wire ball leaf guard

The plastic coated wire ball is an effective, yet economical leaf guard, which is able to prevent small debris entering the roof outlet.

Sizes: ten standard sizes available: 50 to 160mm.



Overflow insert

Used in conjunction with rainwater outlets to provide an overflow roof drainage system by increasing the drainage height to 25 or 35mm above roof level.

Manufactured from 316 grade stainless steel.

Available from stock for 110mm diameter outlets (75mm option available to order).



90° Pipe angle

The stainless steel 90° angle is used for outlet connection into the drainage system or from a parapet outlet into a hopper. A 90° pipe angle for the wide parapet outlet is also available for manufacture to order (allow 2 weeks).

D, diameter (mm)	X1 (mm)	X2 (mm)	R (mm)
50	86	40	50
75	107	53	75
110	134	73	110
160	181	105	171

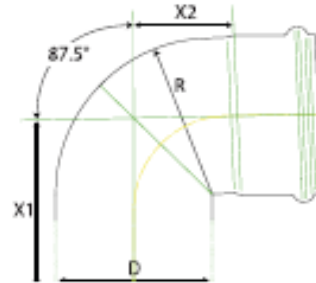

Terrace leaf guard

Axter terrace leaf guard's walls are manufactured from 1mm stainless steel Aisi 304.

Inspection and cleaning of the outlet is possible via the removable perforated grill manufactured from 1.5mm stainless steel Aisi 304 allowing light foot traffic when secured in place (as shown below).

The terrace leaf guards come in 3 different adjustable heights (L1) with a minimum height of 60mm (L2).

- TLG/6090: 60mm to 90mm.
- TLG/90120: 90mm to 120mm.
- TLG/120150: 120mm to 150mm.

Terrace leaf guards are made to order (allow 2 weeks)

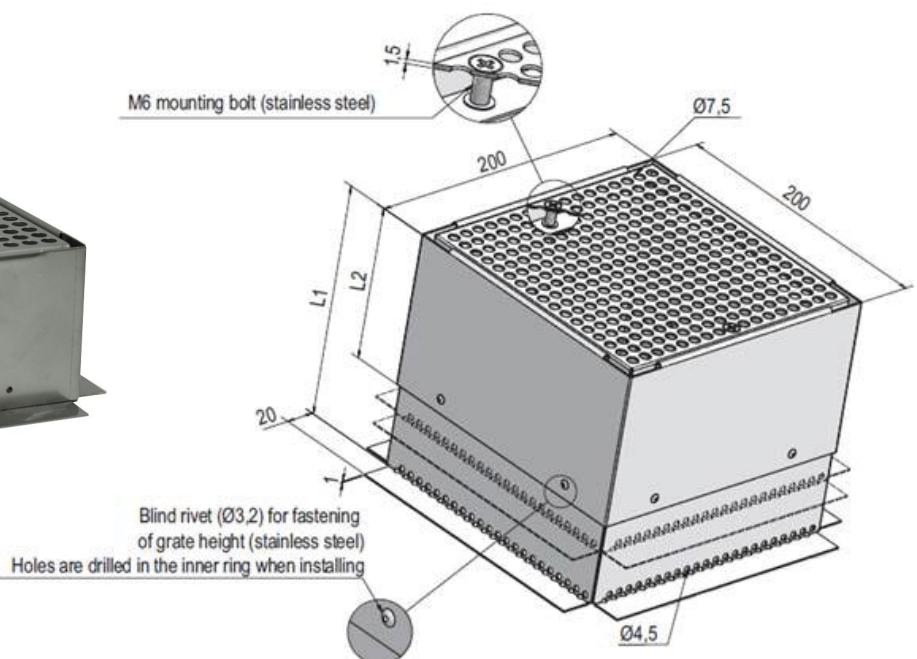

Mechanical seal

The mechanical seal includes a patented mechanical compression technique to form a watertight seal within the outlet stem and existing rainwater downpipe.

It is made of robust nylon flanges and stainless steel screws providing torque strength to compress the EPDM rubber gasket which expands outwards to form the seal.

The mechanical seal comes in 3 different sizes:

Relaxed seal diameter min – max (mm)	Compressed seal diameter min-max (mm)
66.00 – 80.50	72.40 – 84.33
89.70 – 116.07	95.00 – 110.49
136.90 – 167.39	146.30 – 168.40

Select the correct seal size prior to installation by measuring the internal diameter of existing pipework. The seal should be inserted into the outlet stem and the stainless steel screws tightened using the Mechanical Seal installation tool, also available from Axter Ltd, until the top half of the seal has expanded. The whole component is then placed into the new or existing roof drainpipe.

The stainless steel screws are then further tightened until hand tight which will expand the bottom half of the seal against the drainpipe.

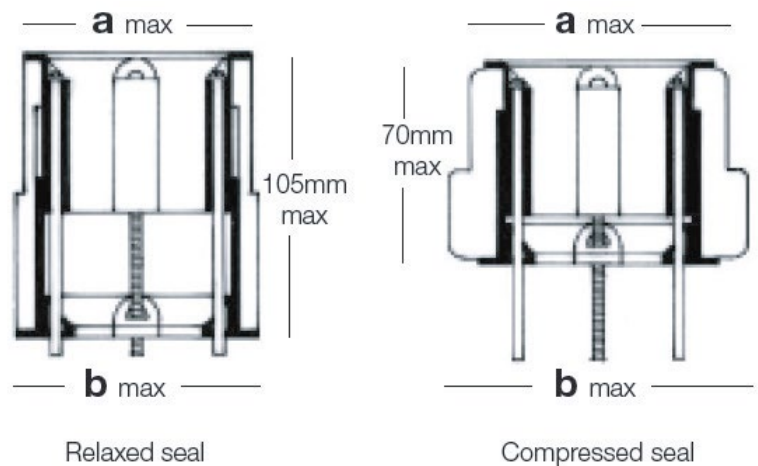

Mechanical seal installation tool

For tightening the seal, a No. 2 square drive screwdriver of the correct length is required. Contact Axter Ltd for details of the specialist hand screwdriver available.



Axter Ltd reserves the right to modify and update this data at any time without prior notice. Only the latest version of this document is valid, available for download at www.axter.co.uk/downloads. Once downloaded, documents are uncontrolled. Users should always confirm they are referring to the latest version prior to use. Further assistance is available from Axter Ltd's Technical Support Team, email: technical@axterltd.co.uk, telephone: 01473 935008.

The intended use of this product should be verified with Axter Ltd prior to adoption to ensure its suitability and compliance with specifications, project requirements, industry regulations, legislation, good practice, installation techniques and all other relevant guidance. Axter Ltd accepts no liability for non-compliant use of this product.